

**Paranchi manuali
a catena serie CX**

CX series manual chain hoists

KITO

SERIE CX

Con portata 250, 500 e 1000 kg

CX SERIES
WLL250, 500 and 1000 kg

CARATTERISTICHE
SPECIFICATION

- CX serie includes three small manual chain hoists, with WLL 250 Kg, 500 Kg and 1000 Kg
- Aluminium body, only 2,4 Kg (CX003) and 4,5 Kg net weight (CX005)
- Very compact, only 217 mm between hooks (CX003) and 260 mm (CX005)
- Only 15 Kg (CX003) and 19 Kg (CX005) hand pull to lift full load
- Kito nickel plated load chain, greatly resistant to corrosion and wear
- Overload limiter against accidental overloading
- The unit can be operated from -40°C to 60°C

- La serie CX comprende 3 paranchi di dimensioni ridottissime, con portata 250 Kg, 500 Kg e 1000 Kg
- Realizzati in alluminio, pesano solo 2,4 Kg (CX003) e 4,5 Kg (CX005)
- Compattissimi, solo 217 mm tra i ganci (CX003) e 260 mm (CX005)
- Sforzo sulla catena di manovra di solo 15 Kg (CX003) e 19 Kg (CX005)
- Catena di carico al nichel, con elevata resistenza alla corrosione e alla fatica
- Limitatore di carico di serie
- Temperatura di utilizzo: -40°C / 60°C



TIPO CX003
CX003 TYPE



TIPO CX005
CX005 TYPE

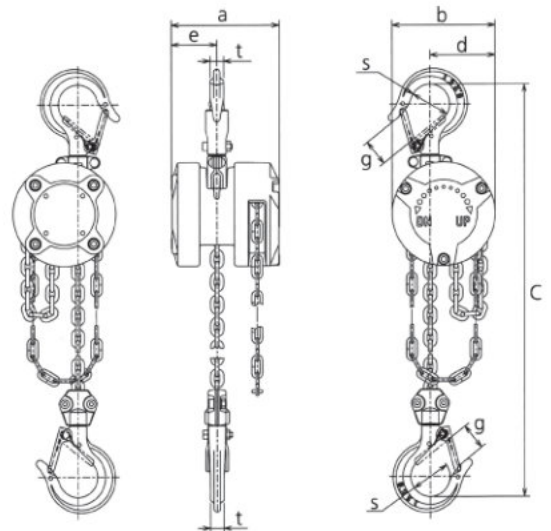

Paranchi manuali a catena serie CX

CX series manual chain hoists

KITO

SERIE CX

Con portata 250, 500 e 1000 kg

CX SERIES
WLL250, 500 and 1000 kg

DATI TECNICI TECHNICAL DATA

Portata WLL	Tipo Type	Corsa gancio STD Std lift	Catena di manovra STD Std Hand chain	Sforzo sulla catena di manovra a pieno carico Hand pull to lift full load	Catena svolta per sollevare 1 m Chain pulled to lift load 1 m	Catena di carico Load chain		Carico di prova Test load	Peso con 3 m di corsa gancio Weight with 3 m lift	Peso per ogni metro addizionale di corsa gancio Weight for additional one meter of lift
						Diametro x tiri Diameter x falls	n°			
Kg		m	m	daN	m	mm	n°	Kg	Kg	Kg/m
250	CX003	3	3	14,7	33,8	3,2	1	310	2,4	0,4
500	CX005	3	3	18,7	42,8	4,3	1	630	4,5	0,9
1000	CX010	3	3	19,3	85,6	4,3	2	1250	7,3	7,8

Portata WLL	Tipo Type	Dimensioni Dimensions							
		a mm	b mm	c mm	d mm	e mm	g mm	s mm	t mm
250	CX003	88	84	217	53	37	21	32	11
500	CX005	102	102	260	66	44	24,5	35,5	12
1000	CX010	103	122	360	44	87	29	42,5	15

